

“Putting the Pieces Together” 4th Grade Curriculum Night

Bernadette Marshalek 4A
Kelly Natale 4B
Amy Twidwell 4C

Bradford Woods Elementary School
September 13, 2021



Welcome Back to School!



Mrs. Marshalek



Mrs. Twidwell



Mrs. Natale



A Few Pieces of the Puzzle



- iPad
- Blackboard
- Notability
- Google Meet



- Science
- Social Studies
- English



- Math



- Reading
- Spelling
- Writing
- Vocabulary



Where Can Parents Find Information?

- Weekly **Agenda** in (BB)- “What is my child doing today/this week?”
- Subject **Content Folders** – All class/homework assignments are found in Blackboard (BB)
- Link on **NA home page** to navigate Blackboard “Parent View of Blackboard”
- **Assignment Books** – students write daily

Live Lesson Expectations:



Please make sure that your microphone is on mute when you enter.



Make sure your video camera is on and your face is visible.



Plug in your headphones/earbuds to reduce background noise.

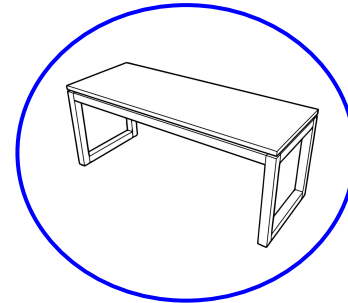

Make sure you have a flat surface that you can write on.



We are not currently using the chat box.

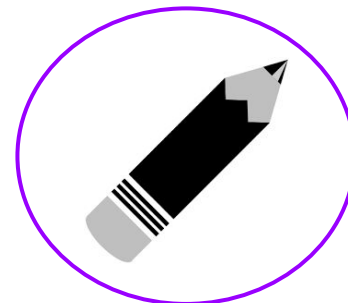

Come prepared to class with whatever materials are needed.



Technology Tips

- Use patience and give grace
- Refer to “4th Grade iPad Bootcamp” for information on apps, logins, email, etc
- Remote learners should join “Google Meet” due to COVID
- Charge the iPad every night
- Complete software updates at home
- Use only for school work
- Keep earbuds handy (case or container at school)
- Follow all “School Ipad Rules”

- **Contact the Help desk for iPad connection or technology issues # 412-369-5849**

Math

GO MATH! (Houghton Mifflin Harcourt)



- Instruction will focus on inquiry-based methodology
- Problem solving will be emphasized in all units
- Pennsylvania Core Standards for Math will be addressed
- Student will receive “mini-books” for all chapters. Students write in these consumable books. The books are available on-line as well.
- Online resources for all lessons include warm-ups, guided lessons, independent work, quick lesson checks, homework, and assessments
- Daily homework
- **WORK IS DONE IN HARD COPY BOOK** and on paper unless otherwise directed.



Math Programs and Applications

Reflex Math



Study Island



Exact Path



Notability



TigerID - The Reflex app helps to master math facts through daily practice. Study Island and Exact Path provide rigorous content and adaptive diagnostics customized to meet the GoMath chapters and state standards.

Notability is our note-taking app.

**Math teachers - Ms. Marshalek 4th grade
(Mr. Turner - 5th grade)**

SCIENCE

Four Science Units

- Life Science
 - Earth Science
 - Physical Science
 - Space and Technology
-
- Experiments (Scientific Method)
 - Work is done in paper packet
 - Quizzes and tests - Study guides; study skills; essay questions
 - Research projects (Google Slides, Ipad Project...)
 - **NO online book; books pages available in Blackboard.**

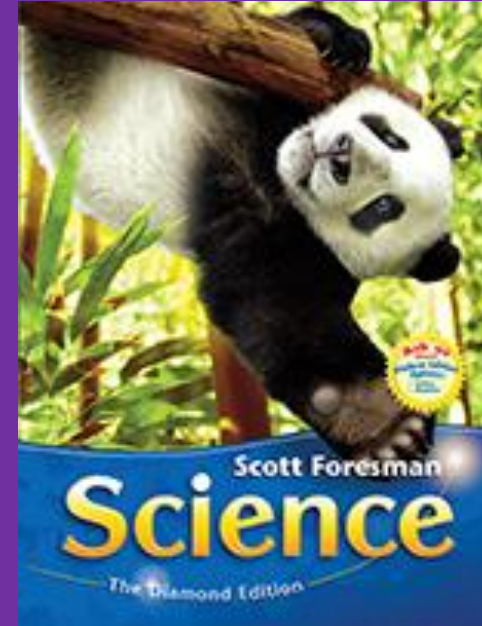

Science teacher - Mrs. Twidwell

SOCIAL STUDIES

KIDS DISCOVER AMERICAN STATES AND REGIONS

- Consumable books/magazine for each region
- Online book available in TigerID and in Mrs. Twidwell's Blackboard Class

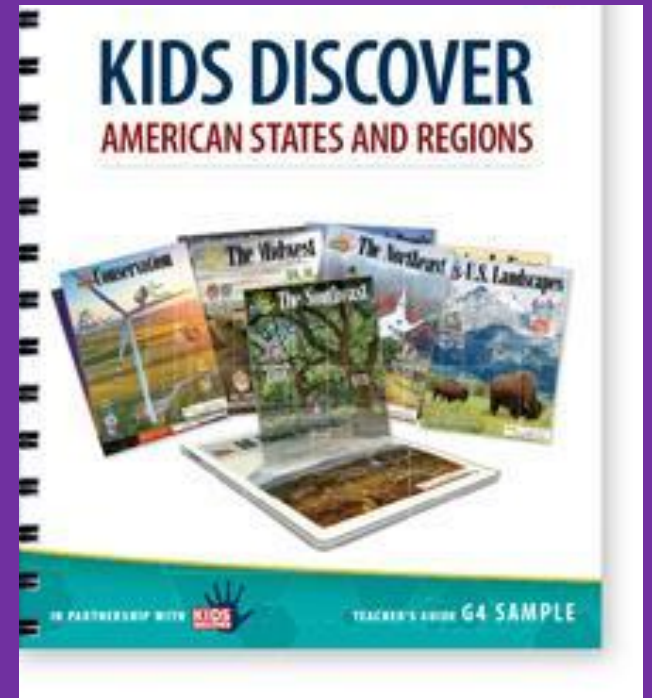

SOCIAL STUDIES CONTENT

Geography

Regions:

Northeast

FIRST REGION TEST - NORTHEAST REGION

Midwest

Southwest

West

States, abbreviations and capitals

Social Studies teacher – Mrs. Twidwell



The background features a purple gradient with four hands holding puzzle pieces. The top-left hand is yellow, holding a red piece. The top-right hand is blue, holding a green piece. The bottom-left hand is brown, holding a blue piece. The bottom-right hand is grey, holding a yellow piece. The puzzle pieces are arranged in a square pattern around the central text.

English Language Arts with Mrs. Natale

Reading - Vocabulary - Spelling - Writing

ELA Components

Vocabulary

- Generative Vocabulary – prefixes, suffixes, Greek/Latin Roots
- Academic Vocabulary – no official weekly test but application
- Vocabulary Skills (context clues, multiple meaning words, etc.)

Writing

- Formal writing lessons are in week 5.
- Journals and written responses

Spelling

- Each list and test will have 16 basic words, 2 review words, and 2 Mastery High Frequency Words.
- Only 3 spelling lists per module
- Spelling homework = Spelling City activities
- Spelling Test = Spelling City

Reading Comprehension

- Strategy and skill development—"what effective readers do"
- Lots of opportunities to respond in writing—"getting the thinking on paper"
- Tests will include both cold reads and/or story assessments.
- Module Assessments for every module.

○

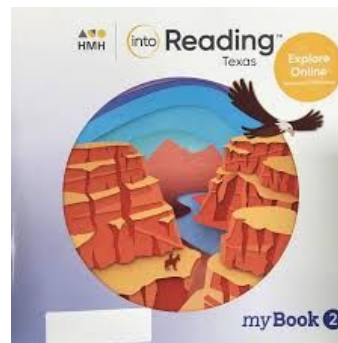
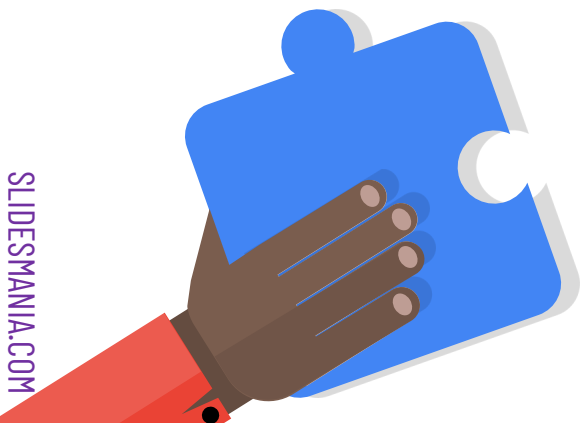

Making Your Thinking Visible– “Show what you know”

1. Answer the question. What does the text say?

Think: How do you know?

2. Provide evidence. What does the text show?

Think: So what?

3. Elaborate on your thinking. What does the text mean?

Weekly Reading Log & Reading Response Journal

- Weekly reading log **due every Friday**
- **Must be signed** in order to get full credit
- Encourage your child to read every day for 15 minutes.
- Four weeks to read a book or more
- Write to a specific prompt about the book—done in class
- Students will “show what they know” and demonstrate analysis of the book and mastery of specific reading skills.
- Will come home to be reviewed by grown-up.



Homework

- Let your child “give it a go” and then support
- Connection to the classroom
- Turned in on time
- Could be paper or online
- Math homework **EVERY** night
- Read every night for 15 minutes
- Will be assigned through Blackboard
- **Check the assignment book**



ELECTRONIC GRADE BOOK (TYLER) AND REPORT CARDS

- Four grading periods (nine weeks)
- On-line report cards with Tyler Link to NA web page
www.northallegheny.org and click on the link or
<https://grades.northallegheny.org>



Contact the Teacher or Office

E-mails

bmarshalek@northallegheny.org

knatale@northallegheny.org

atwidwell@northallegheny.org

Written note

Must send note or email when absent. PLEASE send pickup notes to the homeroom teacher. Copy Marlene Hunter on email notes.

mhunter@northallegheny.org

Message through office 724-935-5081

Technology related questions-

Contact the NA Help Desk 412-369-5849

Thank you!

